

Please check the examination details below before entering your candidate information

Candidate surname

Other names

Centre Number

Candidate Number

--	--	--	--	--

--	--	--	--

## Pearson Edexcel International Advanced Level

Time 1 hour 30 minutes

Paper  
reference

**WPH11/01**

### Physics

International Advanced Subsidiary/Advanced Level  
**UNIT 1: Mechanics and Materials**

**You must have:**

Scientific calculator, ruler, protractor

May/June 2022

Total Marks

### Instructions

- Use **black** ink or ball-point pen.
- **Fill in the boxes** at the top of this page with your name, centre number and candidate number.
- Answer **all** questions.
- Answer the questions in the spaces provided  
– *there may be more space than you need.*
- **Show all your working out** in calculations and **include units** where appropriate.

### Information

- The total mark for this paper is 80.
- The marks for **each** question are shown in brackets  
– *use this as a guide as to how much time to spend on each question.*
- In the question marked with an **asterisk** (\*), marks will be awarded for your ability to structure your answers logically, showing how the points that you make are related or follow on from each other where appropriate.
- The list of data, formulae and relationships is printed at the end of this booklet.

### Advice

- Read each question carefully before you start to answer it.
- Try to answer every question.
- Check your answers if you have time at the end.

Turn over ►

P70968A

©2022 Pearson Education Ltd.

Q:1/1/1/1



  
Pearson

## SECTION A

Answer ALL questions.

For questions 1–10, in Section A, select one answer from A to D and put a cross in the box ☒. If you change your mind, put a line through the box ☒ and then mark your new answer with a cross ☒.

- 1 A machine has a power of 750 W and transfers 150 kJ of energy during a time  $t$ .

Which of the following expressions gives  $t$  in seconds?

- A  $\frac{750}{150}$
- B  $\frac{750 \times 150}{1000}$
- C  $\frac{150 \times 1000}{750}$
- D  $\frac{750}{150 \times 1000}$

(Total for Question 1 = 1 mark)

- 2 A sphere falls through a viscous liquid as shown.

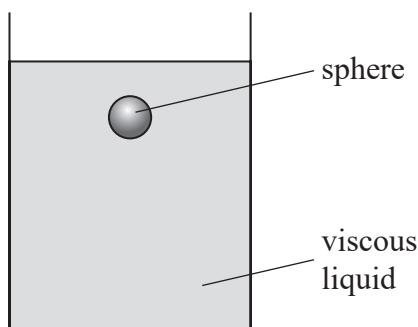

Which row of the table describes the upthrust and the viscous drag on the sphere as it accelerates downwards?

	Upthrust	Viscous drag
<input type="checkbox"/> A	increasing	increasing
<input type="checkbox"/> B	constant	increasing
<input type="checkbox"/> C	increasing	constant
<input type="checkbox"/> D	constant	constant

(Total for Question 2 = 1 mark)



3 Which of the following is a scalar quantity?

- A force
- B momentum
- C velocity
- D work

(Total for Question 3 = 1 mark)

4 The graph shows the relationship between tensile stress and tensile strain for a material.

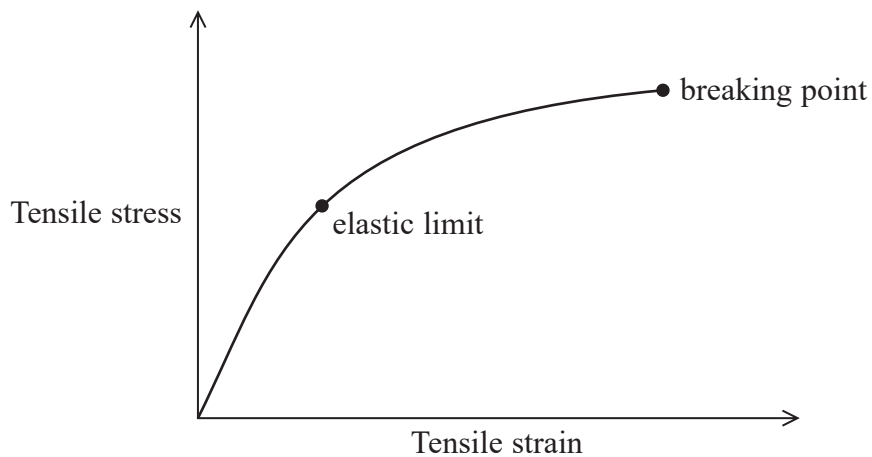

Which of the following gives the Young modulus of the material?

- A the area under the line up to the breaking point
- B the area under the line up to the elastic limit
- C the gradient of the tangent to the line at the origin
- D the stress divided by the strain at the breaking point

(Total for Question 4 = 1 mark)



- 5 A student determined a value for  $g$  by dropping a metal sphere from rest. The student measured the distance fallen and the time taken for the sphere to fall.

The student obtained a value for  $g$  of  $11.2 \text{ m s}^{-2}$ .

Which of the following could explain the difference between the student's value and the accepted value?

- A The air resistance was not negligible.
- B The student's measured distance was greater than the actual distance.
- C The sphere did not fall vertically.
- D The student's measured time was greater than the actual time taken.

(Total for Question 5 = 1 mark)

- 6 A rocket is accelerating horizontally due to a constant resultant force.

The mass of the rocket decreases steadily as it uses up its fuel.

Which graph shows how the acceleration of the rocket could change?

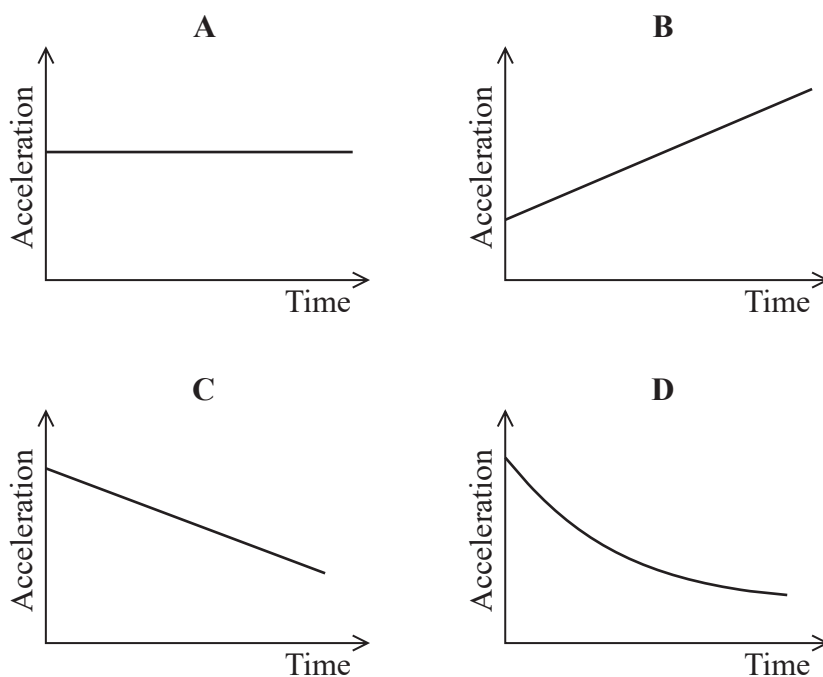

- A
- B
- C
- D

(Total for Question 6 = 1 mark)



DO NOT WRITE IN THIS AREA

- 7 Two arrangements, **P** and **Q**, of identical springs are subjected to the same tensile force  $F$  as shown.

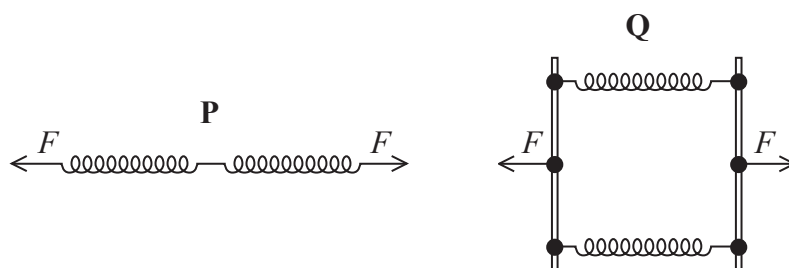

When one spring is subjected to a tensile force  $F$ , the elastic strain energy for the spring is  $E$ .

Which row of the table gives the total elastic strain energy for each arrangement?

	<b>P</b>	<b>Q</b>
<input type="checkbox"/> <b>A</b>	$\frac{1}{2}E$	$2E$
<input type="checkbox"/> <b>B</b>	$\frac{1}{2}E$	$\frac{1}{2}E$
<input type="checkbox"/> <b>C</b>	$2E$	$2E$
<input type="checkbox"/> <b>D</b>	$2E$	$\frac{1}{2}E$

(Total for Question 7 = 1 mark)

- 8 The velocity-time graph shows the motion of a particle with a constant acceleration. **P**, **Q** and **R** represent the magnitudes of each area shown.

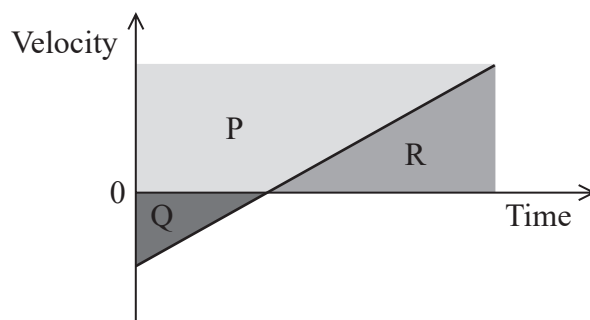

Which of the following expressions gives the total displacement of the particle?

- A**  $P + Q$
- B**  $P + Q - R$
- C**  $R + Q$
- D**  $R - Q$

(Total for Question 8 = 1 mark)

DO NOT WRITE IN THIS AREA

DO NOT WRITE IN THIS AREA



- 9 A cyclist rode along a slope at a constant speed. The increase in vertical height of the cyclist was  $\Delta h$ . The slope was at an angle  $\theta$  to the horizontal as shown.

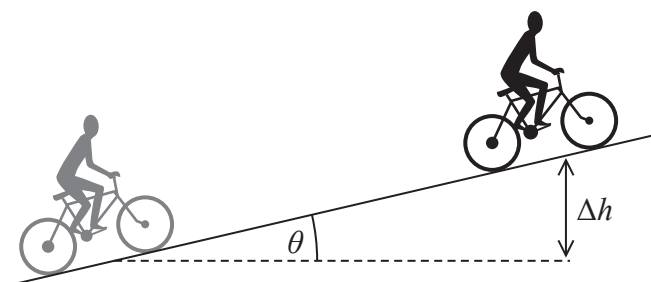

The forward force of the road on the bicycle was  $F$  and air resistance was negligible.

Which of the following gives the work done by the cyclist?

- A  $F \Delta h \cos \theta$
- B  $\frac{F \Delta h}{\cos \theta}$
- C  $F \Delta h \sin \theta$
- D  $\frac{F \Delta h}{\sin \theta}$

(Total for Question 9 = 1 mark)

- 10 When compressed by a force of 50 N, a spring had a length of 12.0 cm.  
When compressed by a force of 70 N, the same spring had a length of 7.1 cm.

Which of the following expressions gives the stiffness  $k$  of the spring in  $\text{N cm}^{-1}$ ?

- A  $\frac{70}{12.0} - \frac{50}{7.1}$
- B  $\frac{(70 - 50)}{(12.0 - 7.1)}$
- C  $\frac{50}{7.1} - \frac{70}{12.0}$
- D  $\frac{(70 - 50)}{(12.0 - 4.9)}$

(Total for Question 10 = 1 mark)

TOTAL FOR SECTION A = 10 MARKS



DO NOT WRITE IN THIS AREA

DO NOT WRITE IN THIS AREA

DO NOT WRITE IN THIS AREA

**BLANK PAGE**



SECTION B

Answer ALL questions in the spaces provided.

11 A disc of mass  $m$  is held stationary by a force  $F$  exerted by a magnetic base, as shown.

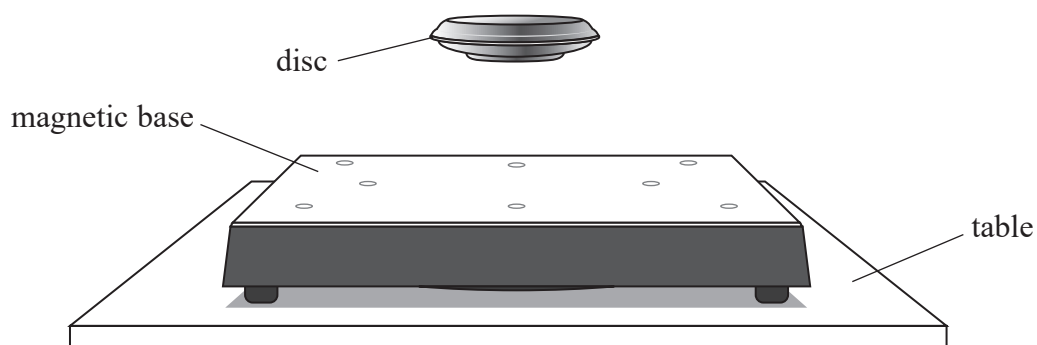

(a) The free-body force diagram for the disc is shown below.



The two forces shown are equal in magnitude and opposite in direction.

Give two reasons why these forces are **not** a Newton's 3rd law pair.

(2)

.....

.....

.....

.....





DO NOT WRITE IN THIS AREA

DO NOT WRITE IN THIS AREA

DO NOT WRITE IN THIS AREA

(b) The magnetic base has weight  $W$  and rests on a horizontal table.

Complete the free-body force diagram below for the magnetic base.

(2)



(Total for Question 11 = 4 marks)



12 When an increasing force is applied to a steel cable it will eventually reach its elastic limit.

(a) State what is meant by the elastic limit.

(1)

(b) The elastic limit of a steel cable was reached when a force of  $13.4 \times 10^6 \text{ N}$  was applied. The extension of the cable was 0.126 m.

length of cable = 6.00 m

cross-sectional area of cable =  $9.60 \times 10^{-3} \text{ m}^2$

(i) Calculate the strain of the cable at its elastic limit.

(2)

Strain = .....

(ii) Calculate the stress in the cable at its elastic limit.

(2)

Stress = .....

(Total for Question 12 = 5 marks)



DO NOT WRITE IN THIS AREA

DO NOT WRITE IN THIS AREA

DO NOT WRITE IN THIS AREA

**BLANK PAGE**



P 7 0 9 6 8 A 0 1 1 2 8

13 A coat hook is attached to a smooth door by a screw as shown.



- (a) The diagram below shows three of the forces that act on the coat hook when a coat is hung from it. The weight of the coat hook may be neglected.

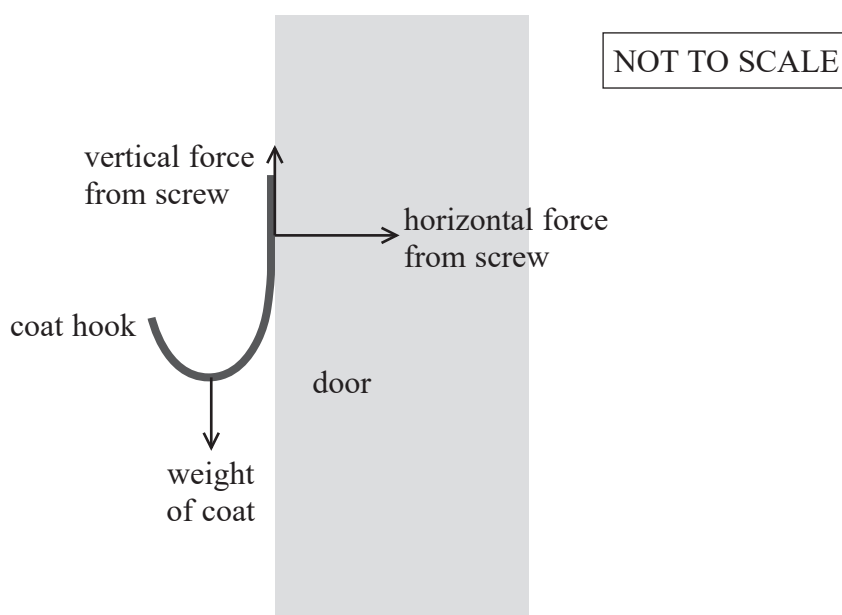

Add a labelled arrow to the diagram to show the additional force required for the coat hook to be in equilibrium.

(2)



- (b) If too many coats are hung on the coat hook, the hook will rotate and pull the screw out of the door. Point P is the position of the pivot as shown.

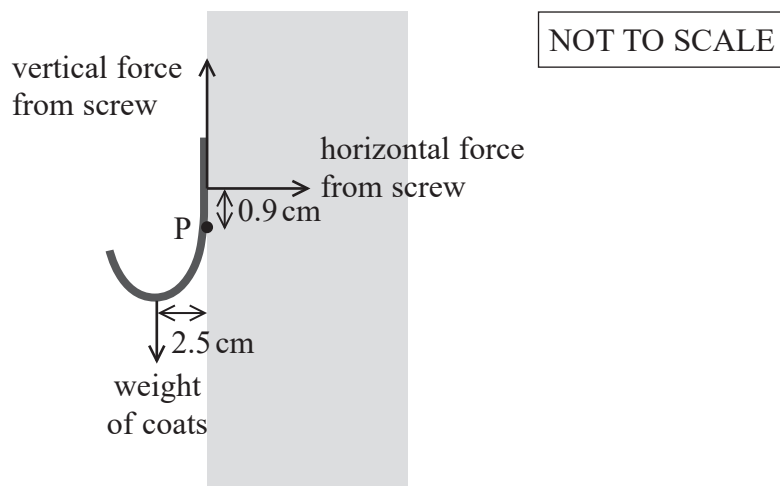

The maximum horizontal force from the screw is 150 N.

The mass of one coat is 2.6 kg.

Deduce whether a person could hang more than two of these coats from the hook.

(4)

(Total for Question 13 = 6 marks)

14 A regenerative braking system allows an electric car to use its kinetic energy to charge a battery as the car decelerates.

(a) A car travelling at  $13.0 \text{ ms}^{-1}$  decelerated to rest.

The energy transferred to the car's battery during the deceleration was  $73.9 \text{ kJ}$ .

Calculate the efficiency of the regenerative braking system.

mass of car =  $1560 \text{ kg}$

(3)

Efficiency = .....



(b) (i) Drag forces act on the car as it moves through the air.

State how the drag forces vary with the velocity of the car.

(1)

(ii) The graph shows how the efficiency of the regenerative braking system depends upon the initial velocity of the car for initial velocities in the range  $20 \text{ m s}^{-1}$  to  $40 \text{ m s}^{-1}$ .

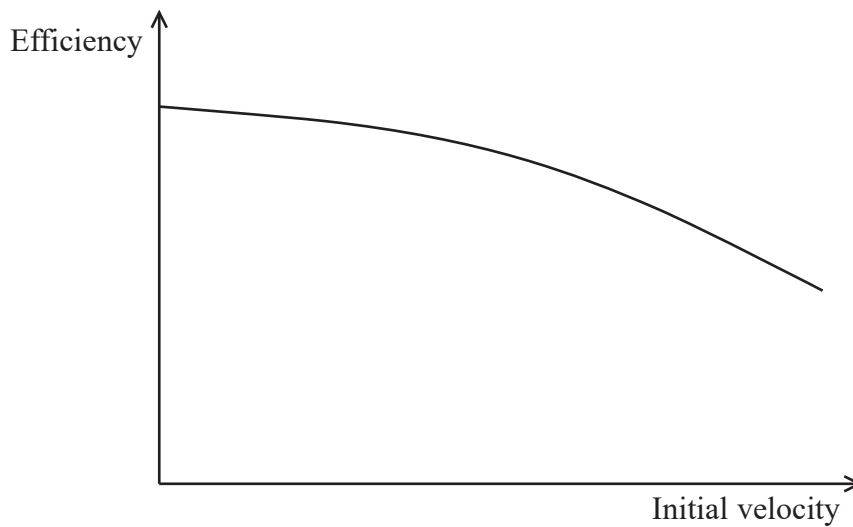

Explain why the efficiency of the regenerative braking system varies as shown in the graph.

(4)

(Total for Question 14 = 8 marks)



P 7 0 9 6 8 A 0 1 5 2 8

\*15 A Galilean thermometer consists of a closed glass cylinder containing a liquid. In the liquid there are several identical sealed glass bulbs, as shown. Attached to each bulb is a metal disc labelled with a temperature. Each disc has a different mass.

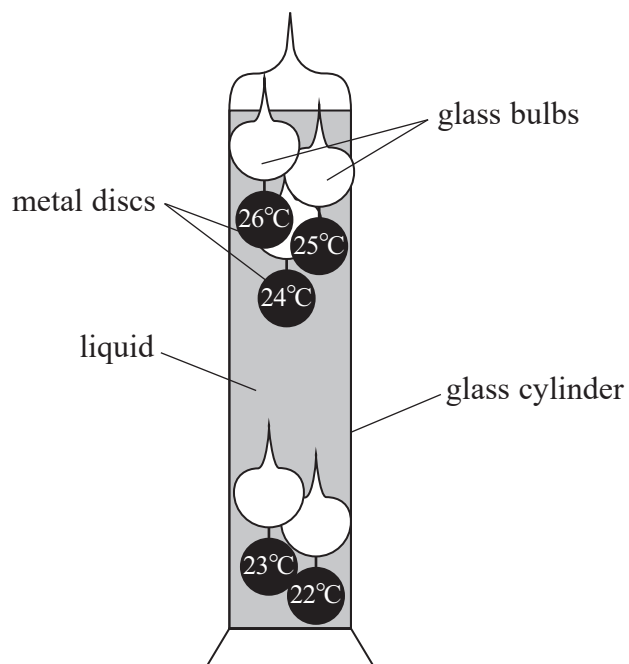

As the temperature increases, the density of the liquid decreases. This can cause the bulbs to move within the liquid.

DO NOT WRITE IN THIS AREA

DO NOT WRITE IN THIS AREA

DO NOT WRITE IN THIS AREA





Explain why a particular bulb will float until the temperature of the liquid exceeds a certain value.

DO NOT WRITE IN THIS AREA

DO NOT WRITE IN THIS AREA

DO NOT WRITE IN THIS AREA

(Total for Question 15 = 6 marks)



P 7 0 9 6 8 A 0 1 7 2 8

16 A student is flying a kite. The kite is held in equilibrium by a string as shown.

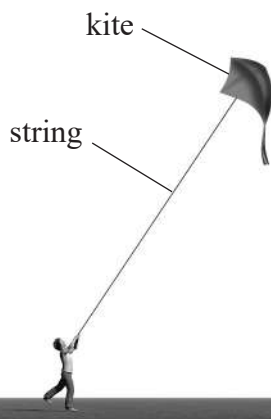

(Source: © CAROL & MIKE WERNER/SCIENCE PHOTO LIBRARY)

The weight of the kite is 24 N, and the wind exerts a force of 70 N at an angle of  $43^\circ$  to the vertical, as shown below.

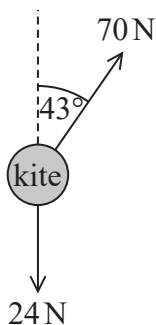

NOT TO SCALE

(a) Determine the magnitude of the tension in the string by using a scaled vector diagram.

(4)

Tension = .....



- (b) The student wants to determine the tension  $T$  in the string. She attaches a mass holder to the string. The student adds known masses to the mass holder until the kite is in equilibrium and part of the string becomes horizontal, as shown.

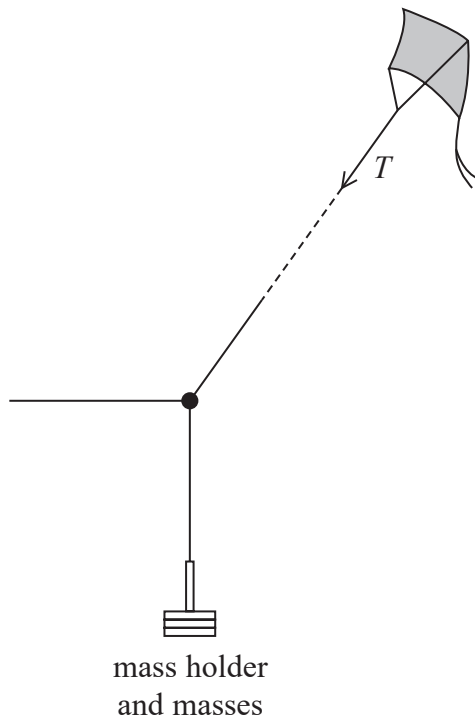

The student takes a photograph of the arrangement.

Describe how the student can use the photograph to determine  $T$ .

(5)

.....

.....

.....

.....

.....

.....

.....

.....

.....

.....

.....

.....

.....

.....

.....

.....

.....

.....

.....

.....

.....

.....

.....

(Total for Question 16 = 9 marks)



17 The diagram shows two bumper cars, P and Q, at an amusement park.

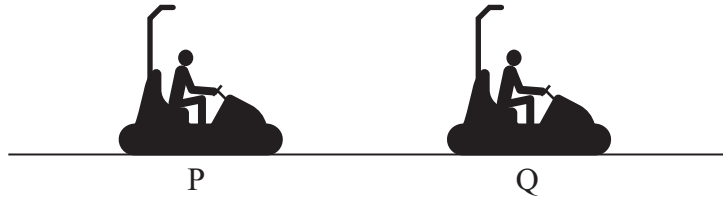

Q was stationary. P was moving at a speed of  $2.10 \text{ ms}^{-1}$  towards Q.

P collided with Q. After the collision, P and Q moved off in the same direction. P moved with a speed of  $1.15 \text{ ms}^{-1}$ . Q moved with a speed of  $1.57 \text{ ms}^{-1}$ .

(a) (i) Show that the total mass of Q was about 150 kg.

total mass of P = 250 kg (3)

.....

.....

.....

.....

.....

.....

.....

(ii) State one assumption you made in your calculation in (a)(i). (1)

.....

.....

(iii) The collision lasted a total time of 1.35 s.  
Calculate the average horizontal force on Q during the collision. (3)

.....

.....

.....

.....

.....

Average horizontal force = .....

DO NOT WRITE IN THIS AREA

DO NOT WRITE IN THIS AREA

DO NOT WRITE IN THIS AREA



DO NOT WRITE IN THIS AREA

DO NOT WRITE IN THIS AREA

DO NOT WRITE IN THIS AREA

(b) Explain why P decelerates during the collision. Your answer should make reference to Newton's laws of motion.

(3)

.....

.....

.....

.....

.....

.....

**(Total for Question 17 = 10 marks)**

.....



- 18 A golfer hit a golf ball into the air at a speed of  $52 \text{ m s}^{-1}$  and an angle of  $41^\circ$  to the horizontal, as shown.

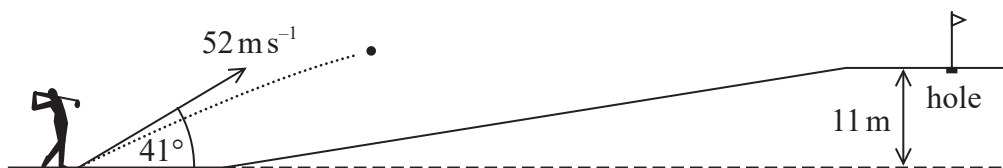

The ball landed on the ground near a hole. The ground was  $11 \text{ m}$  higher than the starting point of the ball.

- (a) Show that the vertical component of the ball's initial velocity was about  $30 \text{ m s}^{-1}$ . (2)

.....

.....

.....

.....

- (b) Show that the time taken by the ball to reach the ground was about  $7 \text{ s}$ . You should ignore the effects of air resistance. (3)

.....

.....

.....

.....

.....

.....

.....

.....

.....



- (c) The hole is a horizontal distance of 250 m from the starting point of the ball, as shown.

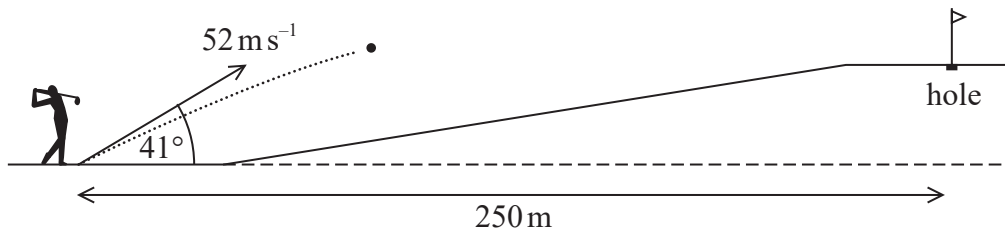

Deduce whether the ball landed within 5.0 m of the hole. You should ignore the effects of air resistance.

(3)

(Total for Question 18 = 8 marks)

19 A falling sphere viscometer is a device used to determine the viscosity of a liquid. A sphere falls through a cylinder containing a liquid, and the terminal velocity of the sphere is measured.

(a) State why the temperature of the liquid should **not** increase during the measurement.

(1)

(b) A scientist measured the terminal velocity of an aluminium sphere as it fell through glycerol.

(i) Show that the weight of the sphere is about  $4.8 \times 10^{-3} \text{ N}$ .

density of aluminium =  $2.70 \times 10^3 \text{ kg m}^{-3}$

diameter of sphere =  $7.00 \times 10^{-3} \text{ m}$

(4)





(ii) The terminal velocity of the sphere was  $4.05 \times 10^{-2} \text{ m s}^{-1}$ .

Deduce whether Stokes' law applied to the falling sphere.

density of glycerol =  $1.26 \times 10^3 \text{ kg m}^{-3}$

viscosity of glycerol =  $9.50 \times 10^{-1} \text{ Pa s}$

(3)

(iii) State one condition that must be met for Stokes' law to apply.

(1)

DO NOT WRITE IN THIS AREA

DO NOT WRITE IN THIS AREA

DO NOT WRITE IN THIS AREA



P 7 0 9 6 8 A 0 2 5 2 8

- (c) A scientist used the viscometer to measure the viscosity of blood. The viscosity of blood is typically in the range  $3 \times 10^{-3}$  Pa s to  $4 \times 10^{-3}$  Pa s.

Explain why the scientist should use an aluminium sphere with a much smaller diameter than the sphere used with the glycerol. Do not include calculations in your answer.

viscosity of glycerol =  $9.50 \times 10^{-1}$  Pa s

(5)

(Total for Question 19 = 14 marks)

**TOTAL FOR SECTION B = 70 MARKS**

**TOTAL FOR PAPER = 80 MARKS**



## List of data, formulae and relationships

Acceleration of free fall	$g = 9.81 \text{ m s}^{-2}$	(close to Earth's surface)
Gravitational field strength	$g = 9.81 \text{ N kg}^{-1}$	(close to Earth's surface)

### Unit 1

#### Mechanics

Kinematic equations of motion	$s = \frac{(u + v)t}{2}$
	$v = u + at$
	$s = ut + \frac{1}{2}at^2$
	$v^2 = u^2 + 2as$

Forces	$\Sigma F = ma$
	$g = \frac{F}{m}$
	$W = mg$

Momentum	$p = mv$
----------	----------

Moment of force	moment = $Fx$
-----------------	---------------

Work and energy	$\Delta W = F\Delta s$
-----------------	------------------------

$$E_k = \frac{1}{2}mv^2$$

$$\Delta E_{\text{grav}} = mg\Delta h$$

Power	$P = \frac{E}{t}$
-------	-------------------

$$P = \frac{W}{t}$$

Efficiency	efficiency = $\frac{\text{useful energy output}}{\text{total energy input}}$
------------	--

$$\text{efficiency} = \frac{\text{useful power output}}{\text{total power input}}$$

#### Materials

Density	$\rho = \frac{m}{V}$
---------	----------------------

Stokes' law	$F = 6\pi\eta rv$
-------------	-------------------

Hooke's law	$\Delta F = k\Delta x$
-------------	------------------------

Elastic strain energy	$\Delta E_{\text{el}} = \frac{1}{2}F\Delta x$
-----------------------	---

Young modulus	$E = \frac{\sigma}{\varepsilon}$ where
---------------	--

$$\text{Stress } \sigma = \frac{F}{A}$$

$$\text{Strain } \varepsilon = \frac{\Delta x}{x}$$



DO NOT WRITE IN THIS AREA

DO NOT WRITE IN THIS AREA

DO NOT WRITE IN THIS AREA

**BLANK PAGE**

